

Jongen Werkzeugtechnik GmbH & Co. KG

# Fresas Para Ranuras en T según DIN 650

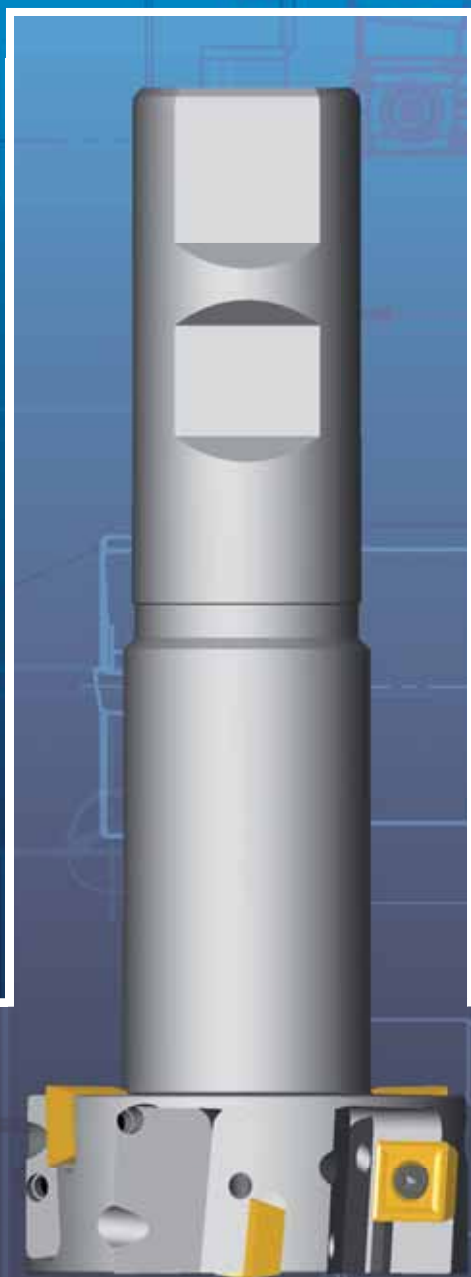

## DESCRIPCIÓN DE HERRAMIENTA

- Fresas para ranuras en T según DIN 650
- Las herramientas son adecuadas para fresar todos los materiales actuales
- Las herramientas están provistas de alimentación de refrigeración interna o canales de refrigeración
- Con alojamiento según DIN 1835

## EJEMPLOS DE EMPLEO

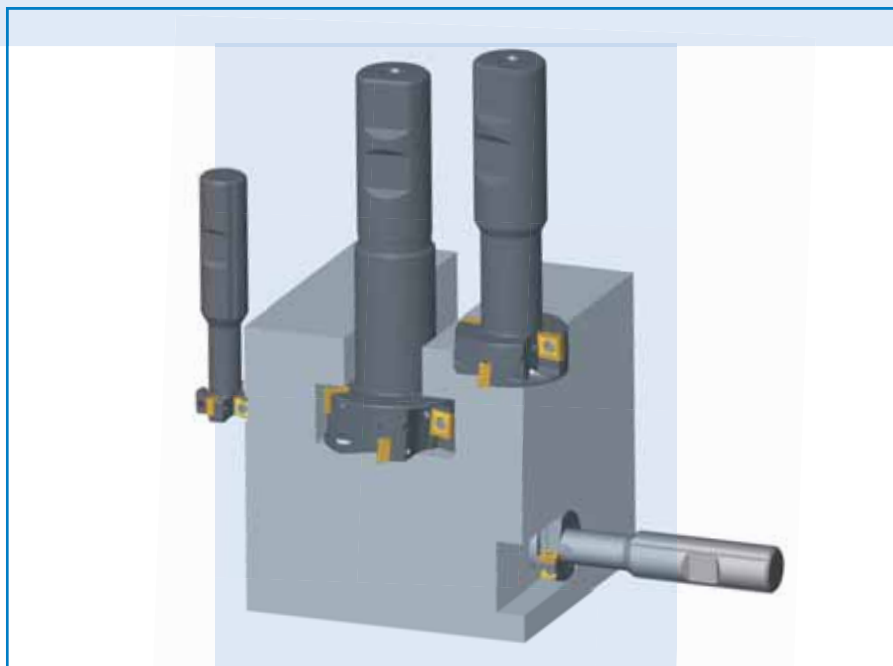

## DATOS TÉCNICOS

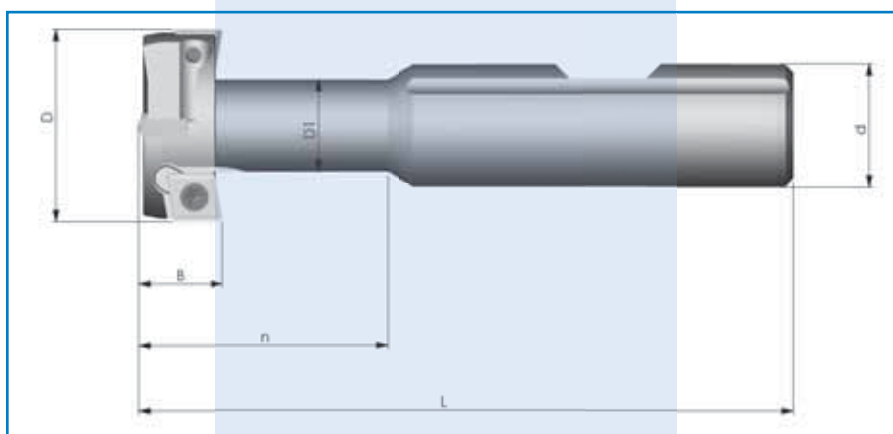

Código	D	D1	B	L	n	d	ZZ	Z
90TN-21-09-65-2	21	11	9	85	32	16	2	4
90TN-25-11-65-2	25	12	11	85	32	16	2	4

## PLAQUITAS



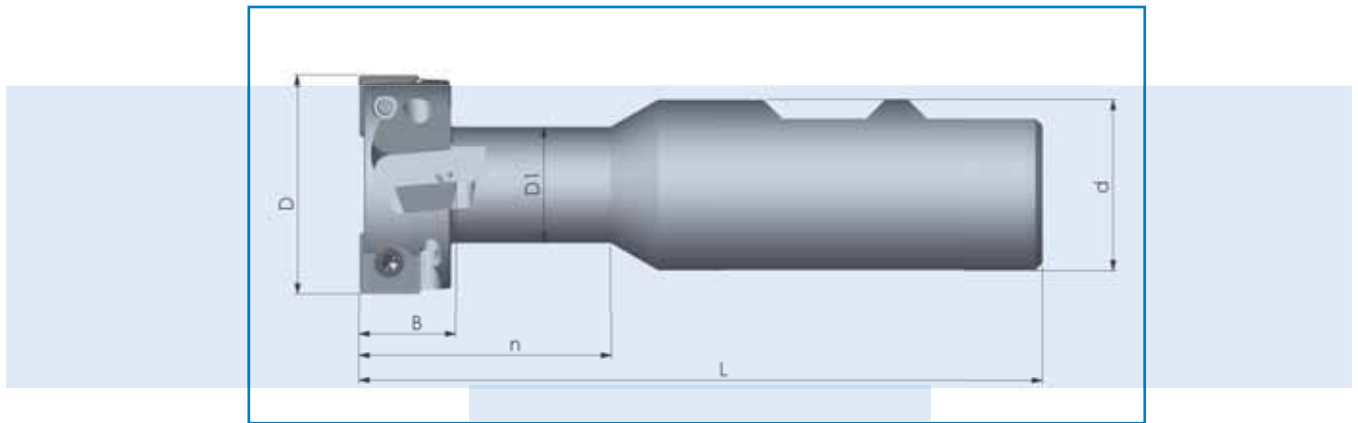

	FP 65 (B9)	Areas de empleo: 1 - 6 (ver la página 4)
--	---------------	--

## DATOS TÉCNICOS



Código	D	D1	B	L	n	d	ZZ	Z
90TN-32-14-328-2	32	17	14	100	37	25	2	4
90TN-40-16-328-2	40	21	16	110	50	25	2	4
90TN-50-21-328-2	50	27	21	130	69	25	2	6





## PLAQUITAS

 9,0x9,0x3,97 r=0,6	FP 327 (B12)	Areas de empleo: 1 - 6 (ver la página 4)
 9,0x9,0x3,97 r=0,6	FP 328 (B12)	Areas de empleo: 1 - 6 (ver la página 4)
 9,0x9,0x3,97 r=0,8	FP 332 (B12)	Areas de empleo: 4 & 7 (ver la página 4)
 9,0x9,0x3,97 r=0,6	FP 348 (B12)	Areas de empleo: 5 & 6 (ver la página 4)

Números de identificación de clases: TI20=1 TA50=2 SR30=3 P25M=6 HS20=7 K15M=8 TIN-HSSE=9 AL10=10 KD10=11 MG15=12 MG30=13  
KT20=14 KT25=15 KD16=16 HT35=19

Unidad de embalaje: 20 unid

## PIEZAS DE RECAM-

	SS2,5-1	Tornillo de fijación para FP 65
	SS3,0-2	Tornillo de fijación para FP 327, FP 328, FP 332 und FP 348
	T08	Destornillador para FP 65
	T09	Destornillador para FP 327, FP 328, FP 332 und FP 348
	FETT	Grasa de alto rendimiento

## ÁREAS DE APLICACIÓN

Material	Velocidad del corte					
	TA50	HT50	SR30	Ti20	KT25	HT35
<b>1</b> Acero no aleado Acero estructural	150-300	150-350	120-280	200-400	-	-
<b>2</b> Acero de baja aleación	100-300	120-320	100-200	200-300	-	-
<b>3</b> Acero de alta aleación	150-300	170-320	150-250	180-320	-	-
<b>4</b> Acero libre herrumbre Aceros finos	80-400	80-400	150-250	-	-	120-250
<b>5</b> Fundición gris	180-350	180-350	-	200-400	160-300	-
<b>6</b> Fundición con grafito nodular	130-250	130-280	-	150-250	160-300	-
<b>7</b> Aluminio Materiales plasticos	-	-	-	500-1.000	-	500-1.000
<b>8</b> Acero templado	-	-	-	-	-	-

Avances de diente	TA50, HT50, SR30	Ti20	KT25	HT35
FP 65	0,05 - 0,25	0,05 - 0,15		
FP 327 / FP 328	0,1 - 0,4	0,1 - 0,3	-	-
FP 348	-	-	0,1 - 0,4	-
FP 332	-	-	-	0,05 - 0,3
FP 330	-	-	-	-

## DISPONIBILIDAD

ex works Willich

01/07



## HPS Service Tools S.L.

Avenida de los Rosales No. 42 • ES-28021 Madrid  
Tel: 901 108 108 • Fax: 913 170 865  
www.jongen.de • email: pedidos@hepresan.es